

15 Displacements	(2.2 - 24.0 in <sup>3</sup> /rev)	
15 Schluckvolumen	36 . . . 390 cm <sup>3</sup> /rev	
15 Cylindrée		
15 Desplazamientos		
	<b>Cont</b>	<b>Int</b>
Maximum Pressure	(1250 psid)	(1750 psid)
Max. Druckgefalle	. . .86 bar	. . .121 bar
Chaute de pression max.		
Presion Maxima		
Maximum Oil Flow	(15 gpm)	
Schluckstrom	. . . 57 lpm	
Débit d'huile		
Caudal Maximo de Aceite		
Maximum Speed	(902 rpm)	
Drehzahl	902 rpm	
Vitesse de rotation		
Velocidad Maxima		
	<b>Cont</b>	<b>Int</b>
Maximum Torque	(1905 lb in)	(2709 lb in)
Max Drehmoment	215.2 Nm	306.1 Nm
Couple Maxi		
Torque Maximo		
Maximum Side Load	(788 lb)	
Seitenlast	. . . 3505 N	
Charges latérales		
Carga Maxima Lateral		

## Big Performance In A Small Package

High Performance and long life in a reduced space envelope describe Parker's TC Series motors. High volume fluid flow continually washes across splines and seals to extend their life. Roller vanes and sealed commutation assure high volumetric efficiency and smooth low speed operation.

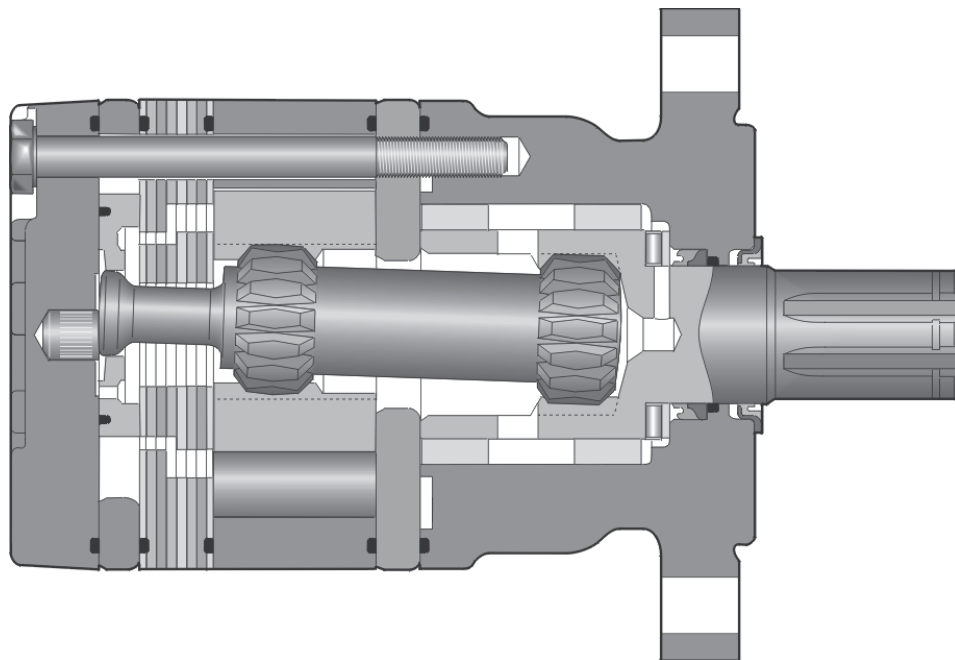

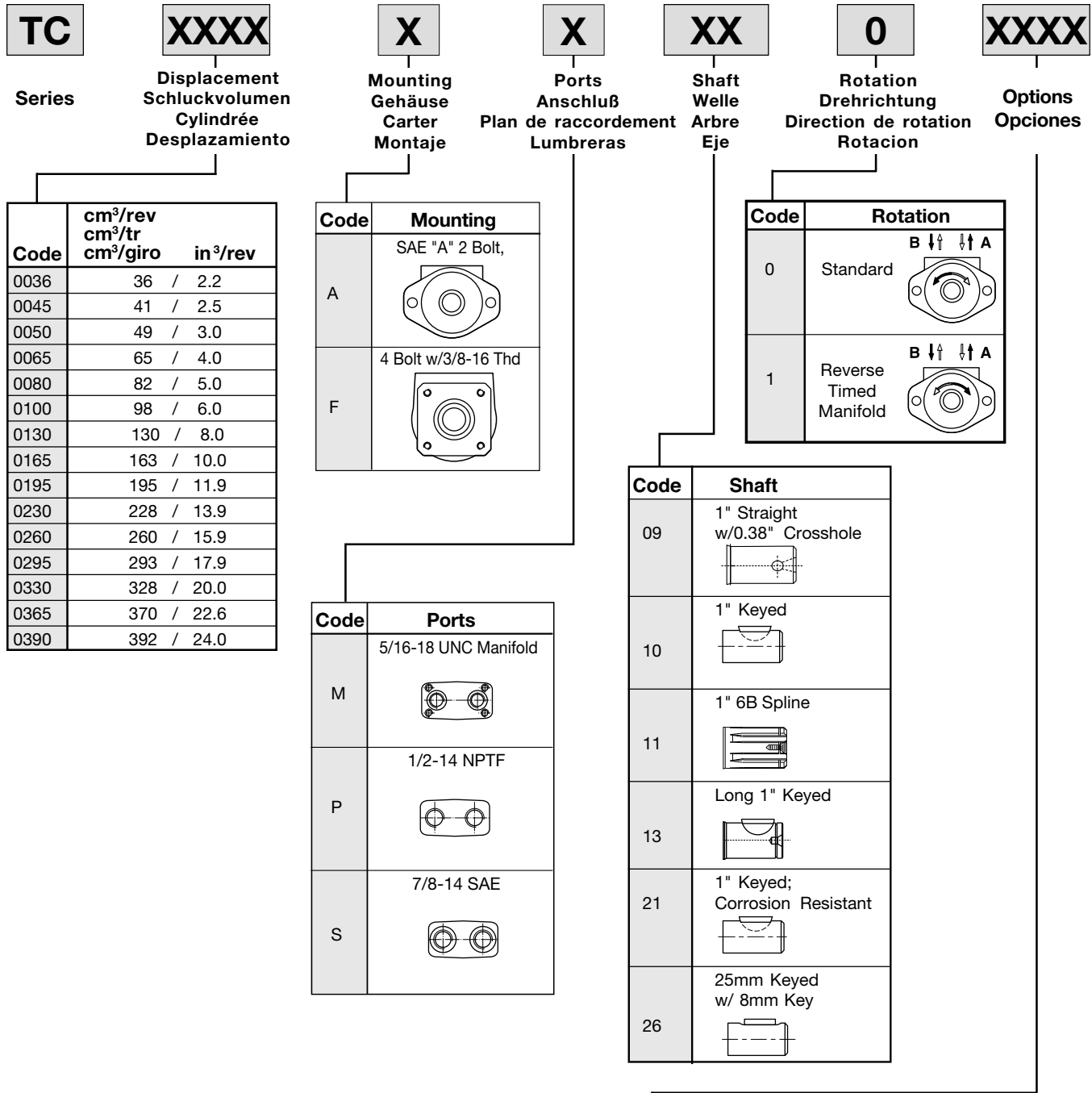

Code	cm <sup>3</sup> /rev cm <sup>3</sup> /tr cm <sup>3</sup> /giro	in <sup>3</sup> /rev
0036	36 /	2.2
0045	41 /	2.5
0050	49 /	3.0
0065	65 /	4.0
0080	82 /	5.0
0100	98 /	6.0
0130	130 /	8.0
0165	163 /	10.0
0195	195 /	11.9
0230	228 /	13.9
0260	260 /	15.9
0295	293 /	17.9
0330	328 /	20.0
0365	370 /	22.6
0390	392 /	24.0

Code	Mounting
A	SAE "A" 2 Bolt, 
F	4 Bolt w/3/8-16 Thd 

Code	Ports
M	5/16-18 UNC Manifold 
P	1/2-14 NPTF 
S	7/8-14 SAE 

Code	Rotation
0	Standard 
1	Reverse Timed Manifold 

Code	Shaft
09	1" Straight w/0.38" Crosshole 
10	1" Keyed 
11	1" 6B Spline 
13	Long 1" Keyed 
21	1" Keyed; Corrosion Resistant 
26	25mm Keyed w/ 8mm Key 

Code	Options
AAAA	Black Paint
AAAB	No Paint
AAAC	Double Paint
AAAG	Viton Seals, Black Paint
AAAH	Viton Seals, No Paint
AAAJ	High Temperature Commutator Seal, Black Paint
AAFG	High Temperature Commutator Seal, No Paint
AABJ*	Free Running Rotorset, Black Paint
AABK*	Free Running Rotorset, No Paint

TC Series are not available rear ported.  
 For other available options, see pages 102–103.

\*Not applicable to TC0365 or TC0390 displacements

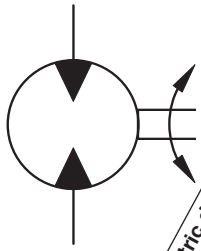

Geometric displacement  
Geom. Schluckvolumen  
Cylindrée  
Desplazamientos

Max. speed @ Max. intermittent flow  
Max. Drehzahl Intermittierender Betrieb:  
Vitesse de rotation maxi  
Velocidad maxima a caudal intermitente maximo

Max. oil flow  
Max. Schluckstrom  
Débit d'huile maxi  
Caudal Maximo de Aceite

Max. Differential Pressure  
Max. Druckgefälle  
Chute de pression maxi  
Presion diferencial maxima

Max. supply pressure  
Max. Eingangsdruck  
Presion maxi entrée  
Presion maxima de alimentacion

Max. torque  
Max. Drehmoment  
Couple maxi  
Torque Maximo

Max. performance  
Max. Leistungabgabe  
Maximo redinamiento

Min. starting torque  
Min. Anlaufmoment  
Couple min. fourni au dé manrage  
Torque minimo de arranque

Motor Series TC	cm³/rev in³/rev	rev/min	cont / int* l/min g/min		cont / int* bar psid		max bar psig	cont / int* Nm lb-in		max KW HP	cont / int* Nm lb-in	
TC 0036	36 2.2	902	34 9	34 9	86 1250	121 1750	134 1950	31 272	44 393	4.2 5.6	16 138	27 236
TC 0045	41 2.5	794	34 9	34 9	86 1250	121 1750	134 1950	40 351	56 496	4.5 6.1	20 174	33 295
TC 0050	49 3.0	688	34 9	34 9	86 1250	121 1750	134 1950	48 423	67 589	4.7 6.3	27 235	39 349
TC 0065	65 4.0	517	34 9	34 9	86 1250	121 1750	134 1950	66 582	92 810	4.8 6.5	41 361	67 590
TC 0080	82 5.0	413	34 9	34 9	86 1250	121 1750	134 1950	96 753	119 1050	4.9 6.6	61 539	86 758
TC 0100	98 6.0	460	45 12	45 12	86 1250	121 1750	134 1950	100 888	140 1240	6.1 8.2	78 691	106 934
TC 0130	130 8.0	429	45 12	57 15	86 1250	121 1750	134 1950	138 1218	192 1697	7.5 10.1	111 986	169 1492
TC 0165	163 10.0	346	45 12	57 15	86 1250	121 1750	134 1950	173 1529	238 2110	7.5 10.0	139 1232	209 1846
TC 0195	195 11.9	287	45 12	57 15	86 1250	121 1750	134 1950	205 1815	286 2532	7.3 9.8	195 1724	264 2332
TC 0230	228 13.9	246	45 12	57 15	76 1100	107 1550	134 1950	215 1905	298 2637	6.3 8.4	195 1722	261 2310
TC 0260	260 15.9	217	45 12	57 15	66 950	97 1400	134 1950	211 1870	306 2709	5.4 7.3	183 1618	265 2344
TC 0295	293 17.9	193	45 12	57 15	59 850	86 1250	134 1950	208 1843	300 2657	4.7 6.3	189 1675	269 2379
TC 0330	328 20.0	173	45 12	57 15	52 750	76 1100	134 1950	206 1819	296 2621	4.0 5.3	187 1655	262 2318
TC 0365	370 22.6	152	45 12	57 15	45 650	66 950	134 1950	206 1825	296 2622	3.4 4.6	186 1648	276 2443
TC 0390	392 24.0	144	45 12	57 15	45 650	66 950	134 1950	207 1832	296 2622	3.2 4.3	192 1698	286 2527

Performance data based on testing using 10W40 oil with a viscosity of 43,1 cSt. (200 SUS) at 54° C (130° F). Performance data is typical. Actual data may vary slightly from one production motor to another.

Les donnees sur les performances sont basees sur des tests utilisant de l'huile 10W40 d'une viscosite de 200 SUS a 54°C (130°F). Ces donnees correspondent a des situations typiques. Les donnees reelles peuvent varier legerement d'un moteur de production a l'autre.

Leistungsdaten sind gemessen mit SAE 10W40 bei einer Viskosität von 43,1 Cst bei 54°C. Geringfügige Abweichungen von den Katalogdaten sind möglich.

Datos tecnicos obtenidos con aceite 10W40 de 200 SUS de viscosidad a 54°C (130°F). Los datos proporcionados son valores tipicos. Los valores exactos reales podrian tener una pequena variacion entre distintos motores.

\* Intermittent operation rating applies to 10% of every minute.  
Intermittierende Werte maximal 10% von jeder Betriebsminute.  
Fonctionnement interm. 10% max. de chaque minute d'utilisation.  
Capacidad de funcionamiento intermitente valida para 10% por cada minuto.

TC 0036

2.2 cu in / rev PRESSURE (PSID)

	500	750	1000	1250	1500	1750
.5	104 27	160 18	214 8			
1	108 78	167 67	222 57	277 45	328 28	380 12
2	109 179	169 170	229 160	287 147	344 130	396 111
3	107 283	172 272	235 262	293 248	351 229	405 208
4	105 387	168 375	236 365	295 350	353 332	410 311
5	103 490	166 478	233 468	295 451	354 434	412 410
7	90 695	156 685	220 673	286 656	348 635	410 610
9	76 903	142 889	208 876	272 860	332 839	393 812

Flow (GPM)

TORQUE (LB IN) 272  
SPEED (RPM) 860

36 cm³/rev

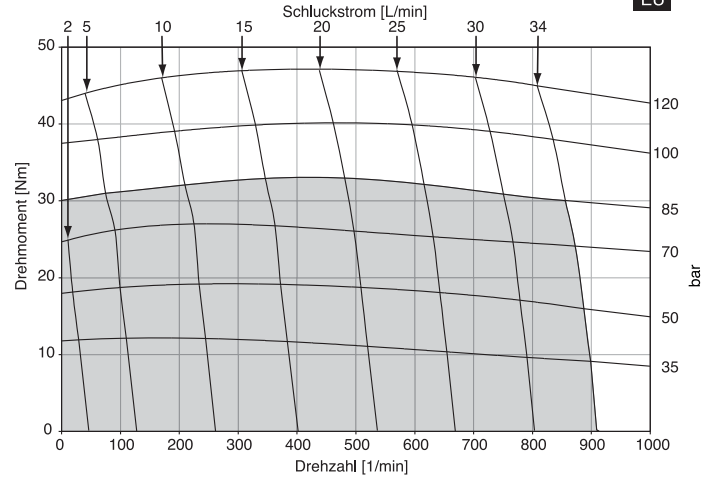

TC 0045

2.5 cu in / rev PRESSURE (PSID)

	500	750	1000	1250	1500	1750
.5	124 22	200 13	254 7			
1	131 73	202 67	270 61	332 51	403 42	
2	131 163	201 157	279 149	350 141	412 130	481 114
3	127 255	201 248	279 241	352 231	424 208	496 208
4	122 346	192 339	279 330	350 321	421 310	498 292
5	113 436	183 429	270 420	341 410	412 399	489 381
7	105 615	174 606	262 594	332 583	403 569	481 547
9	93 793	168 784	249 770	324 757	397 739	473 717

Flow (GPM)

TORQUE (LB IN) 324  
SPEED (RPM) 757

41 cm³/rev

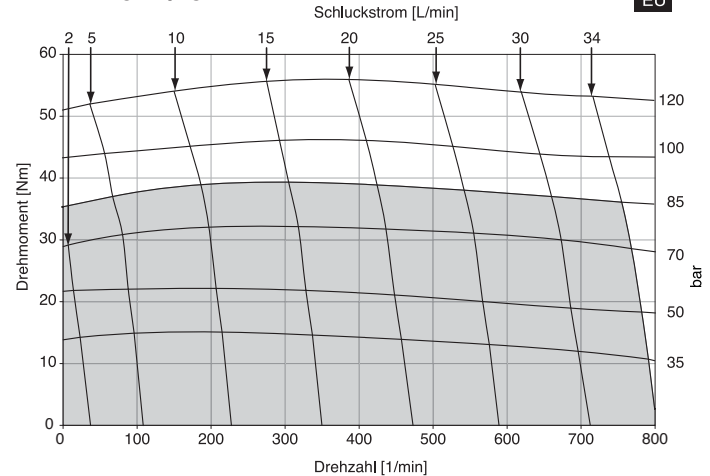

■ Cont. □ Int.

Intermittent operation rating applies to 10% of every minute.

Fonctionnement interm. 10% max. de chaque minute d'utilisation.

Performance data based on testing using 10W40 oil with a viscosity of 200 SUS at 54° C (130° F). Performance data is typical. Actual data may vary slightly from one production motor to another.

Les données sur les performances sont basées sur des tests utilisant de l'huile 10W40 d'une viscosité de 200 SUS à 54°C (130°F). Ces données correspondent à des situations typiques. Les données réelles peuvent varier légèrement d'un moteur de production à l'autre.

Intermittierende Werte maximal 10% von jeder Betriebsminute.

Capacidad de funcionamiento intermitente valida para 6 segundos por cada minuto.

Leistungsdaten sind gemessen mit SAE 10W40 bei einer Viskosität von 43,1 Cst bei 54°C. Geringfügige Abweichungen von den Katalogdaten sind möglich.

Datos tecnicos obtenidos con aceite 10W40 de 200 SUS de viscosidad a 54°C (130°F). Los datos proporcionados son valores tipicos. Los valores exactos reales podrian tener una pequena variacion entre distintos motores.

TC 0050

3.0 cu in / rev PRESSURE (PSID)

	500	750	1000	1250	1500	1750
<b>.5</b>	136 28	210 17				
<b>1</b>	148 59	226 51	305 42	377 33		
<b>2</b>	155 136	238 129	331 117	413 107	476 95	543 79
<b>3</b>	154 215	245 207	334 197	417 186	496 173	573 157
<b>4</b>	148 292	238 284	331 273	422 263	503 251	578 228
<b>5</b>	139 369	233 361	330 350	420 340	506 327	587 305
<b>7</b>	131 519	224 511	325 498	418 486	506 470	591 445
<b>9</b>	123 672	216 661	314 646	405 632	492 615	579 592

Flow (GPM)

TORQUE (LB IN) 405  
SPEED (RPM) 632

49 cm³/rev

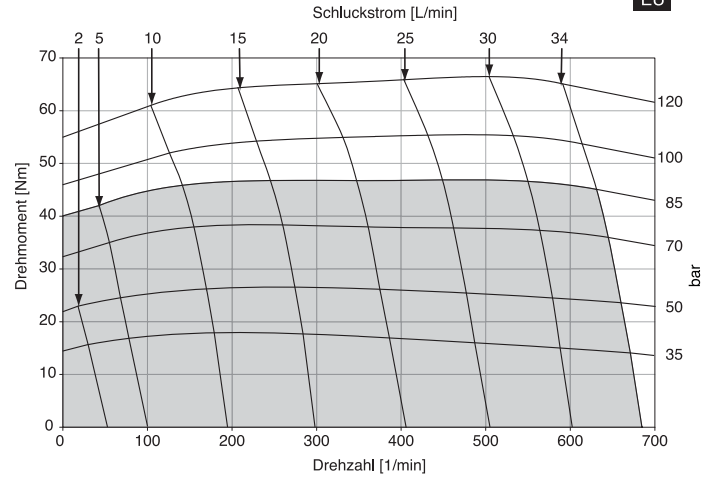

TC 0065

4.0 cu in / rev PRESSURE (PSID)

	500	750	1000	1250	1500	1750
<b>.5</b>	207 14	333 9	425 3			
<b>1</b>	218 47	334 43	449 36	561 30	668 23	
<b>2</b>	231 104	352 100	471 93	583 87	700 79	797 68
<b>3</b>	218 163	341 158	463 151	582 145	697 138	811 126
<b>4</b>	209 220	330 216	462 209	574 202	695 195	808 182
<b>5</b>	201 278	320 273	449 266	571 260	688 251	801 238
<b>7</b>	186 391	311 386	439 376	563 370	682 359	799 344
<b>9</b>	176 506	297 498	427 490	547 480	675 467	796 450

Flow (GPM)

TORQUE (LB IN) 547  
SPEED (RPM) 480

65 cm³/rev

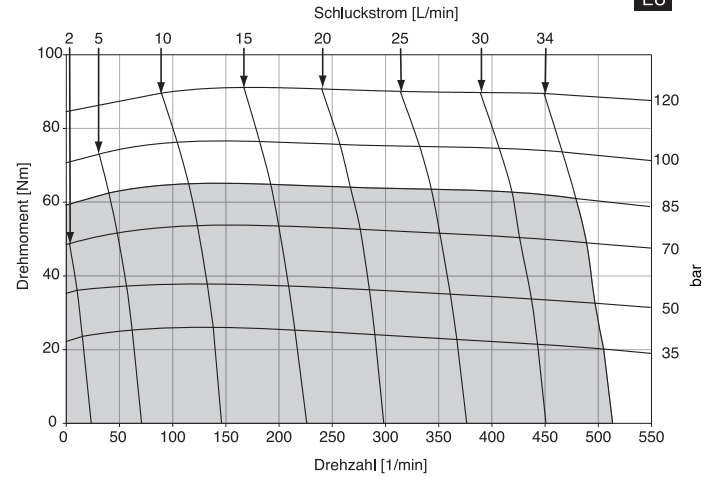

Intermittent operation rating applies to 10% of every minute.

Fonctionnement interm. 10% max. de chaque minute d'utilisation.

Performance data based on testing using 10W40 oil with a viscosity of 200 SUS at 54° C (130° F). Performance data is typical. Actual data may vary slightly from one production motor to another.

Les donnees sur les performances sont basees sur des tests utilisant de l'huile 10W40 d'une viscosite de 200 SUS a 54°C (130°F). Ces donnees correspondent a des situations typiques. Les donnees reelles peuvent varier legerement d'un moteur de production a l'autre.

Intermittierende Werte maximal 10% von jeder Betriebsminute.

Capacidad de funcionamiento intermitente valida para 6 segundos por cada minuto.

Leistungsdaten sind gemessen mit SAE 10W40 bei einer Viskosität von 43,1 Cst bei 54°C. Geringfügige Abweichungen von den Katalogdaten sind möglich.

Datos tecnicos obtenidos con aceite 10W40 de 200 SUS de viscosidad a 54°C (130°F). Los datos proporcionados son valores tipicos. Los valores exactos reales podrian tener una pequena variacion entre distintos motores.

■ Cont. □ Int.

TC 0080

5.0 cu in / rev PRESSURE (PSID)

	500	750	1000	1250	1500	1750
<b>.5</b>	270 14	431 10	558 8	700 3		
<b>1</b>	289 39	438 37	585 33	730 30	871 25	
<b>2</b>	291 86	445 83	599 78	753 75	918 70	1037 61
<b>3</b>	284 132	442 129	600 125	753 121	903 116	1049 108
<b>4</b>	272 179	431 176	563 171	745 167	897 162	1046 153
<b>5</b>	255 225	414 221	574 217	730 212	882 207	1033 198
<b>7</b>	239 315	396 312	559 306	714 300	867 294	1021 284
<b>9</b>	226 407	382 402	547 394	703 389	855 382	1011 369

Flow (GPM)

TORQUE (LB IN) 703  
SPEED (RPM) 389

82 cm³/rev

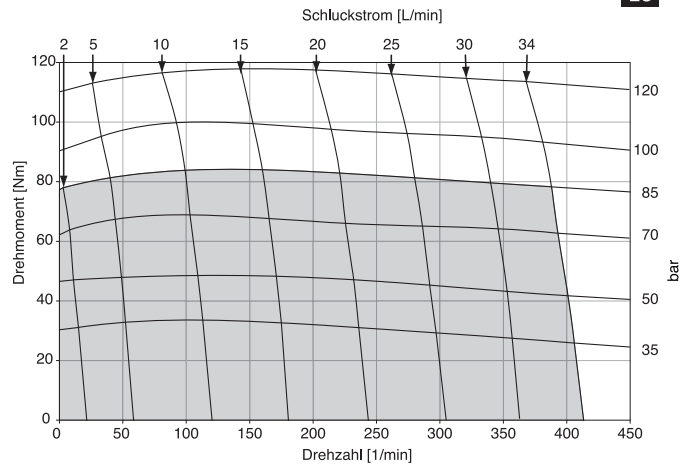

TC 0100

6.0 cu in / rev PRESSURE (PSID)

	500	750	1000	1250	1500	1750
<b>.5</b>	319 8	485 4				
<b>1</b>	337 30	514 26	684 22	855 18	1022 14	
<b>2</b>	345 67	546 64	728 61	909 56	1087 51	1222 44
<b>3</b>	335 108	522 104	707 100	888 96	1065 92	1243 84
<b>4</b>	323 146	508 142	697 139	879 135	1059 130	1241 123
<b>5</b>	305 185	490 181	681 177	864 173	1044 168	1227 161
<b>7</b>	282 261	465 256	658 251	842 247	1024 241	1209 232
<b>9</b>	262 337	444 332	638 326	822 322	1005 315	1193 304
<b>12</b>	203 448	384 443	582 438	763 433	943 427	1121 412

Flow (GPM)

TORQUE (LB IN) 763  
SPEED (RPM) 433

98 cm³/rev

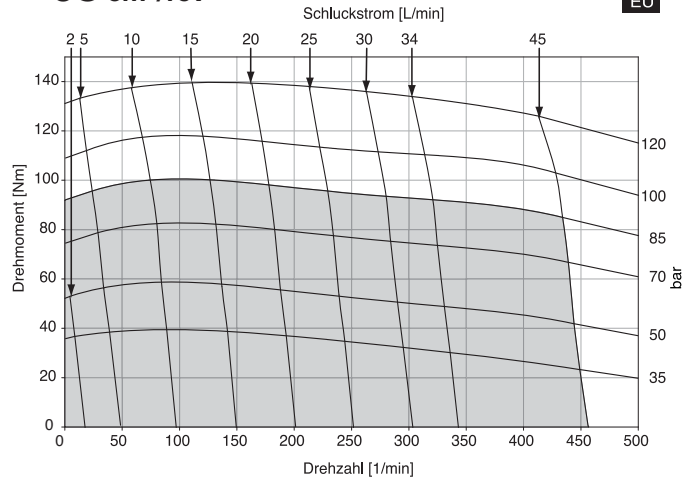

Intermittent operation rating applies to 10% of every minute.

Fonctionnement interm. 10% max. de chaque minute d'utilisation.

Performance data based on testing using 10W40 oil with a viscosity of 200 SUS at 54° C (130° F). Performance data is typical. Actual data may vary slightly from one production motor to another.

Les données sur les performances sont basées sur des tests utilisant de l'huile 10W40 d'une viscosité de 200 SUS à 54°C (130°F). Ces données correspondent à des situations typiques. Les données réelles peuvent varier légèrement d'un moteur de production à l'autre.

Intermittierende Werte maximal 10% von jeder Betriebsminute.

Capacidad de funcionamiento intermitente valida para 6 segundos por cada minuto.

Leistungsdaten sind gemessen mit SAE 10W40 bei einer Viskosität von 43,1 Cst bei 54°C. Geringfügige Abweichungen von den Katalogdaten sind möglich.

Datos tecnicos obtenidos con aceite 10W40 de 200 SUS de viscosidad a 54°C (130°F). Los datos proporcionados son valores tipicos. Los valores exactos reales podrian tener una pequena variacion entre distintos motores.

■ Cont. □ Int.



TC 0130

8.0 cu in / rev PRESSURE (PSID)

	500	750	1000	1250	1500	1750
.5	447 9	718 7	921 5	1188 2		
1	472 25	717 23	960 21	1201 19	1442 17	
2	476 54	726 52	970 50	1213 48	1455 45	1698 40
3	461 83	710 82	961 79	1204 76	1448 74	1693 70
4	440 112	689 111	942 108	1188 106	1432 103	1677 100
5	417 141	663 139	918 137	1164 135	1408 132	1654 129
7	384 198	629 195	857 193	1102 191	1346 188	1597 184
9	308 256	533 256	792 252	1034 250	1279 246	1533 241
12	270 342	499 340	758 337	998 334	1239 330	1492 324
15	188 428	418 426	677 422	911 420	1144 416	1391 412

Flow (GPM)

TORQUE (LB IN) 1533  
SPEED (RPM) 241

130 cm<sup>3</sup>/rev

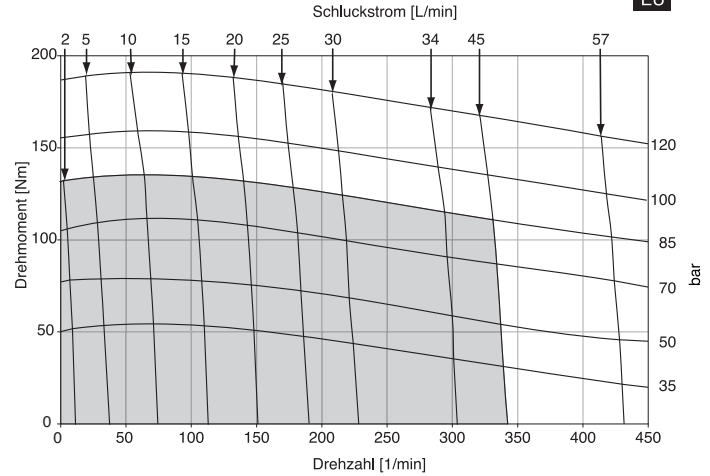

TC 0165

10.0 cu in / rev PRESSURE (PSID)

	500	750	1000	1250	1500	1750
.5	554 8	881 6	1130 4	1457 2		
1	594 20	898 19	1197 17	1492 16	1785 14	
2	605 43	914 42	1220 41	1526 39	1819 38	2114 35
3	584 67	899 66	1211 64	1518 63	1833 61	2109 58
4	554 91	866 89	1183 89	1491 87	1791 86	2092 85
5	519 114	827 113	1146 111	1455 110	1755 109	2057 108
7	477 159	782 158	1102 156	1408 155	1707 153	2011 150
9	376 207	671 205	991 204	1290 202	1587 201	1894 198
12	323 248	613 247	933 245	1229 244	1519 243	1833 241
15	194 347	467 345	786 344	1073 342	1363 341	1673 340

Flow (GPM)

TORQUE (LB IN) 1894  
SPEED (RPM) 198

163 cm<sup>3</sup>/rev

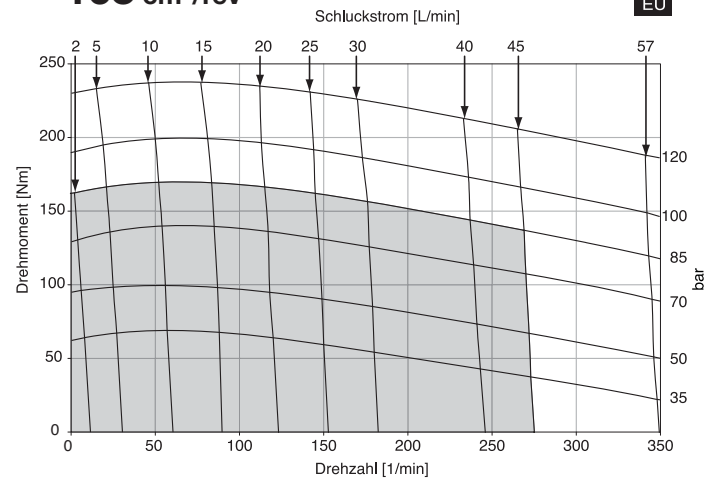

■ Cont. □ Int.

Intermittent operation rating applies to 10% of every minute.

Fonctionnement interm. 10% max. de chaque minute d'utilisation.

Performance data based on testing using 10W40 oil with a viscosity of 200 SUS at 54°C (130°F). Performance data is typical. Actual data may vary slightly from one production motor to another.

Les données sur les performances sont basées sur des tests utilisant de l'huile 10W40 d'une viscosité de 200 SUS à 54°C (130°F). Ces données correspondent à des situations typiques. Les données réelles peuvent varier légèrement d'un moteur de production à l'autre.

Intermittierende Werte maximal 10% von jeder Betriebsminute.

Capacidad de funcionamiento intermitente valida para 6 segundos por cada minuto.

Leistungsdaten sind gemessen mit SAE 10W40 bei einer Viskosität von 43,1 Cst bei 54°C. Geringfügige Abweichungen von den Katalogdaten sind möglich.

Datos tecnicos obtenidos con aceite 10W40 de 200 SUS de viscosidad a 54°C (130°F). Los datos proporcionados son valores típicos. Los valores exactos reales podrian tener una pequeña variacion entre distintos motores.

TC 0195

11.9 cu in / rev PRESSURE (PSID)

	500	750	1000	1250	1500	1750
<b>.5</b>	678 6	1089 5	1402 3			
<b>1</b>	704 17	1070 15	1439 14	1805 13	2166 11	
<b>2</b>	717 36	1089 35	1459 33	1824 32	2176 30	2523 27
<b>3</b>	687 56	1061 55	1427 54	1789 52	2148 51	2508 48
<b>4</b>	650 75	1019 74	1389 73	1749 72	2105 70	2463 67
<b>5</b>	614 95	978 94	1350 92	1708 91	2061 89	2418 86
<b>7</b>	567 132	925 132	1301 131	1656 129	2007 127	2365 124
<b>9</b>	452 201	799 200	1177 199	1526 198	1873 195	2232 192
<b>12</b>	392 227	732 226	1107 225	1454 224	1803 221	2163 218
<b>15</b>	249 290	569 289	944 288	1288 287	1627 285	1985 282

Flow (GPM)

TORQUE (LB IN) 2232  
SPEED (RPM) 192

195 cm<sup>3</sup>/rev

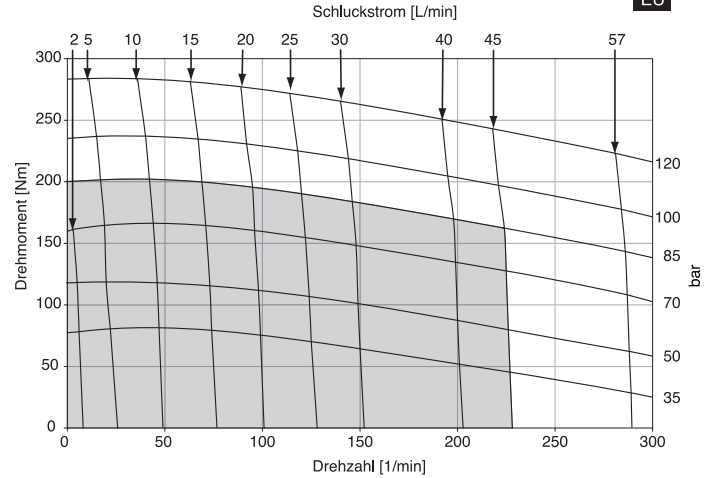

TC 0230

13.9 cu in / rev PRESSURE (PSID)

	500	750	1100	1300	1550
<b>.5</b>	837 4	1313 3			
<b>1</b>	856 14	1293 12	1892 11	2226 9	2637 8
<b>2</b>	846 30	1291 29	1888 28	2221 25	2621 23
<b>3</b>	820 47	1258 46	1853 44	2179 42	2581 41
<b>4</b>	784 64	1217 63	1809 61	2134 60	2531 58
<b>5</b>	741 80	1168 79	1760 78	2086 76	2475 74
<b>7</b>	683 113	1101 112	1692 111	2019 110	2405 106
<b>9</b>	518 146	908 146	1497 144	1833 143	2231 140
<b>12</b>	462 176	851 175	1432 174	1763 173	2153 169
<b>15</b>	337 246	720 244	1291 243	1604 242	1969 237

Flow (GPM)

TORQUE (LB IN) 2231  
SPEED (RPM) 140

228 cm<sup>3</sup>/rev

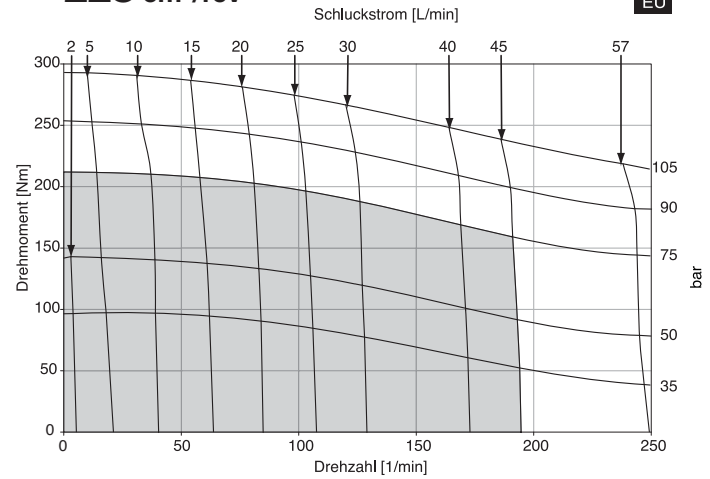

■ Cont. □ Int.

Intermittent operation rating applies to 10% of every minute.

Fonctionnement interm. 10% max. de chaque minute d'utilisation.

Performance data based on testing using 10W40 oil with a viscosity of 200 SUS at 54°C (130°F). Performance data is typical. Actual data may vary slightly from one production motor to another.

Les données sur les performances sont basées sur des tests utilisant de l'huile 10W40 d'une viscosité de 200 SUS à 54°C (130°F). Ces données correspondent à des situations typiques. Les données réelles peuvent varier légèrement d'un moteur de production à l'autre.

Intermittierende Werte maximal 10% von jeder Betriebsminute.

Capacidad de funcionamiento intermitente valida para 6 segundos por cada minuto.

Leistungsdaten sind gemessen mit SAE 10W40 bei einer Viskosität von 43,1 Cst bei 54°C. Geringfügige Abweichungen von den Katalogdaten sind möglich.

Datos tecnicos obtenidos con aceite 10W40 de 200 SUS de viscosidad a 54°C (130°F). Los datos proporcionados son valores tipicos. Los valores exactos reales podrian tener una pequena variacion entre distintos motores.



TC 0260

15.9 cu in / rev PRESSURE (PSID)

	500	750	950	1200	1400
<b>.5</b>	950 5	1446 4	1828 3	2307 2	
<b>1</b>	978 13	1473 12	1860 11	2335 11	2713 10
<b>2</b>	989 27	1489 26	1880 26	2353 25	2728 24
<b>3</b>	946 42	1449 42	1837 41	2307 40	2689 39
<b>4</b>	889 57	1382 56	1775 55	2233 55	2608 54
<b>5</b>	837 71	1316 71	1704 70	2169 70	2536 69
<b>7</b>	765 100	1235 100	1623 100	2078 99	2437 98
<b>9</b>	588 130	1016 129	1391 129	1876 129	2230 128
<b>12</b>	523 155	952 155	1329 155	1767 154	2131 154
<b>15</b>	357 217	796 216	1177 216	1611 216	1969 215

Flow (GPM)

TORQUE (LB IN) 2230  
SPEED (RPM) 128

260 cm<sup>3</sup>/rev

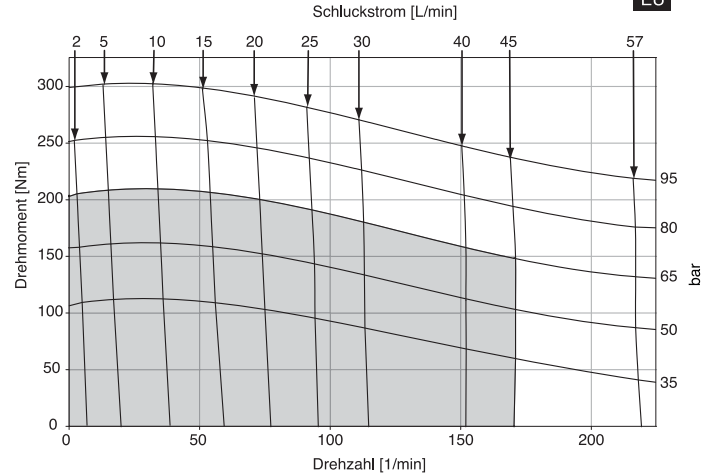

TC 0295

17.9 cu in / rev PRESSURE (PSID)

	500	850	1000	1250
<b>.5</b>	1037 4	1769 2		
<b>1</b>	1075 11	1834 10	2145 9	2656 8
<b>2</b>	1090 23	1850 23	2153 22	2656 21
<b>3</b>	1046 36	1807 36	2110 36	2611 35
<b>4</b>	976 50	1729 49	2040 48	2540 48
<b>5</b>	915 63	1668 62	1970 61	2468 61
<b>7</b>	837 89	1582 88	1883 87	2378 87
<b>9</b>	645 115	1349 114	1648 114	2163 113
<b>12</b>	575 138	1271 137	1569 137	2046 136
<b>15</b>	392 192	1098 191	1377 191	1831 191

Flow (GPM)

TORQUE (LB IN) 2163  
SPEED (RPM) 113

293 cm<sup>3</sup>/rev

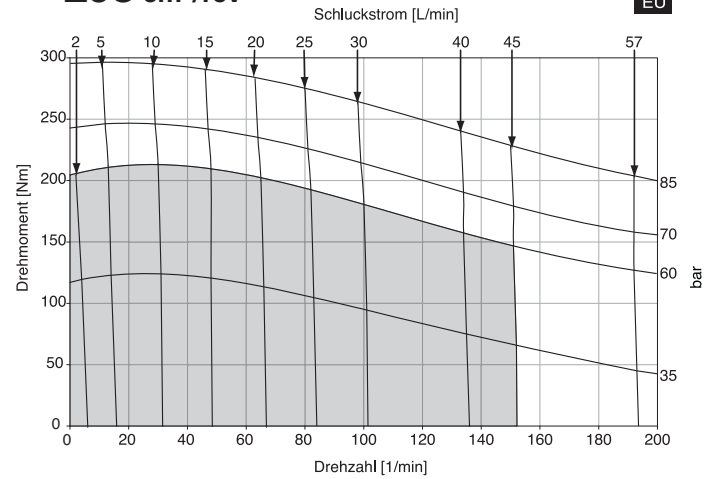

■ Cont. □ Int.

Intermittent operation rating applies to 10% of every minute.

Fonctionnement interm. 10% max. de chaque minute d'utilisation.

Performance data based on testing using 10W40 oil with a viscosity of 200 SUS at 54° C (130° F). Performance data is typical. Actual data may vary slightly from one production motor to another.

Les données sur les performances sont basées sur des tests utilisant de l'huile 10W40 d'une viscosité de 200 SUS à 54°C (130°F). Ces données correspondent à des situations typiques. Les données réelles peuvent varier légèrement d'un moteur de production à l'autre.

Intermittierende Werte maximal 10% von jeder Betriebsminute.

Capacidad de funcionamiento intermitente valida para 6 segundos por cada minuto.

Leistungsdaten sind gemessen mit SAE 10W40 bei einer Viskosität von 43,1 Cst bei 54°C. Geringfügige Abweichungen von den Katalogdaten sind möglich.

Datos tecnicos obtenidos con aceite 10W40 de 200 SUS de viscosidad a 54°C (130°F). Los datos proporcionados son valores típicos. Los valores exactos reales podrian tener una pequeña variacion entre distintos motores.

TC 0330

20.0 cu in / rev PRESSURE (PSID)

	250	500	750	1100
.5	580 4	1177 3		
1	603 10	1207 10	1803 9	2298 7
2	598 22	1232 22	1803 21	2298 19
3	558 34	1158 33	1757 32	2251 32
4	507 46	1098 45	1693 44	2195 44
5	458 57	1033 56	1620 56	2124 55
7	381 80	968 79	1510 79	2030 79
9	226 103	733 102	1272 103	1808 103
12		636 123	1163 123	1706 123
15		426 173	934 172	1485 172

Flow (GPM)

TORQUE (LB IN) 1808  
SPEED (RPM) 103

328 cm<sup>3</sup>/rev

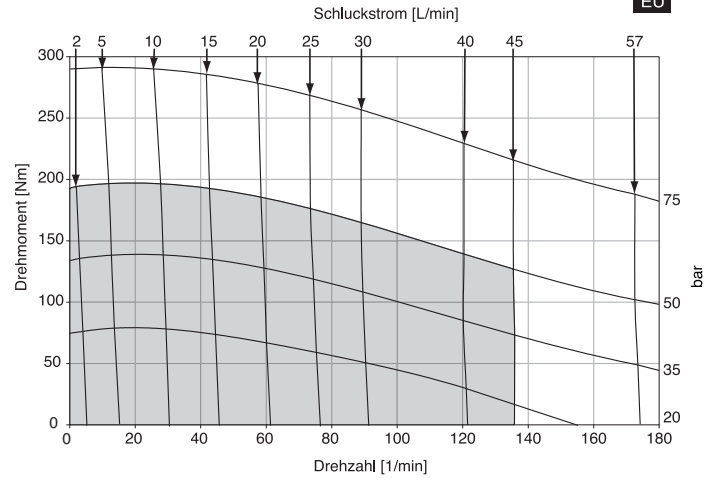

TC 0365

22.6 cu in / rev PRESSURE (PSID)

	250	500	650	950
.5	603 4	1260 3	1689 2	2529 1
1	636 9	1316 8	1745 8	2542 7
2	637 19	1351 18	1772 18	2551 17
3	587 30	1264 29	1684 28	2479 28
4	542 40	1212 39	1622 39	2408 39
5	484 50	1138 50	1550 50	2331 49
7	419 71	1055 70	1463 70	2239 70
9	259 91	793 91	1199 91	2025 91
12		741 108	1155 108	1962 108
15		619 152	1058 152	1828 152

Flow (GPM)

TORQUE (LB IN) 2025  
SPEED (RPM) 91

370 cm<sup>3</sup>/rev

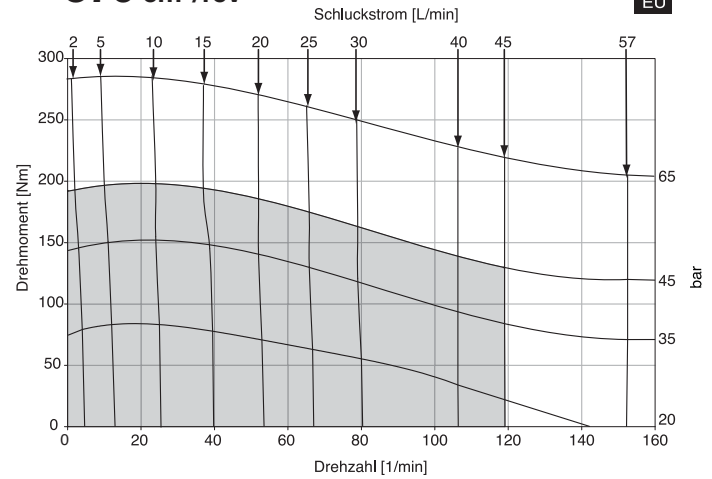

■ Cont. □ Int.

Intermittent operation rating applies to 10% of every minute.

Fonctionnement interm. 10% max. de chaque minute d'utilisation.

Performance data based on testing using 10W40 oil with a viscosity of 200 SUS at 54° C (130° F). Performance data is typical. Actual data may vary slightly from one production motor to another.

Les données sur les performances sont basées sur des tests utilisant de l'huile 10W40 d'une viscosité de 200 SUS à 54°C (130°F). Ces données correspondent à des situations typiques. Les données réelles peuvent varier légèrement d'un moteur de production à l'autre.

Intermittierende Werte maximal 10% von jeder Betriebsminute.

Capacidad de funcionamiento intermitente valida para 6 segundos por cada minuto.

Leistungsdaten sind gemessen mit SAE 10W40 bei einer Viskosität von 43,1 Cst bei 54°C. Geringfügige Abweichungen von den Katalogdaten sind möglich.

Datos tecnicos obtenidos con aceite 10W40 de 200 SUS de viscosidad a 54°C (130°F). Los datos proporcionados son valores tipicos. Los valores exactos reales podrian tener una pequena variacion entre distintos motores.

TC 0390

24.0 cu in / rev PRESSURE (PSID)

	250	500	650	950
<b>.5</b>	671 3	1356 2		
<b>1</b>	694 8	1404 8	1825 7	2622 6
<b>2</b>	694 18	1421 17	1842 17	2604 16
<b>3</b>	648 27	1343 26	1754 26	2533 26
<b>4</b>	587 38	1264 37	1675 37	2453 36
<b>5</b>	534 47	1194 47	1595 46	2363 46
<b>7</b>	458 66	1107 66	1498 66	2265 66
<b>9</b>	282 86	880 85	1260 85	2016 86
<b>12</b>		819 98	1195 98	1942 98
<b>15</b>		540 144	908 143	1623 144

Flow (GPM)

TORQUE (LB IN) 2016  
SPEED (RPM) 86

392 cm<sup>3</sup>/rev

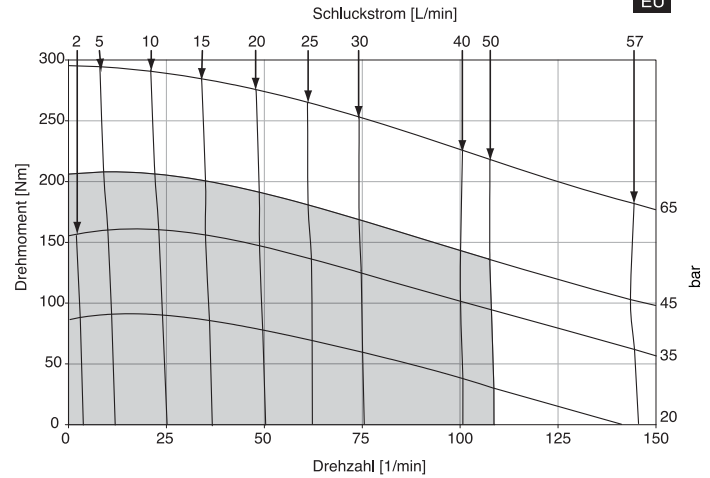

■ Cont. □ Int.

Intermittent operation rating applies to 10% of every minute.

Fonctionnement interm. 10% max. de chaque minute d'utilisation.

Performance data based on testing using 10W40 oil with a viscosity of 200 SUS at 54° C (130° F). Performance data is typical. Actual data may vary slightly from one production motor to another.

Les donnees sur les performances sont basees sur des tests utilisant de l'huile 10W40 d'une viscosite de 200 SUS a 54°C (130°F). Ces donnees correspondent a des situations typiques. Les donnees reelles peuvent varier legerement d'un moteur de production a l'autre.

Intermittierende Werte maximal 10% von jeder Betriebsminute.

Capacidad de funcionamiento intermitente valida para 6 segundos por cada minuto.

Leistungsdaten sind gemessen mit SAE 10W40 bei einer Viskosität von 43,1 Cst bei 54°C. Geringfügige Abweichungen von den Katalogdaten sind möglich.

Datos tecnicos obtenidos con aceite 10W40 de viscosidad a 54°C (130°F). Los datos proporcionados son valores tipicos. Los valores exactos reales podrian tener una pequena variacion entre distintos motores.

Shaft Side Load Capacity N (lb)

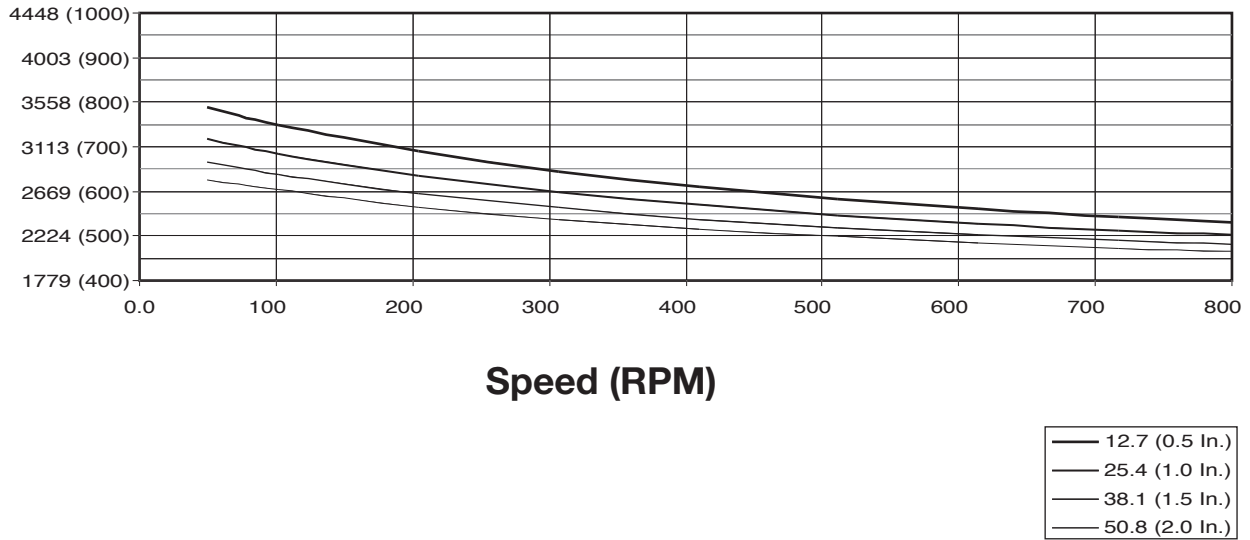

The allowable side load curve is based on bushing life of  $2.5 \times 10^6$  revolutions.

Die zulaessige radiale Wellenbelastung bezieht sich auf die Lager-Lebensdauer  $2,5 \times 10^6$  Umdrehungen.

L'effort radial admissible sur l'arbre depend a une duree de vie  $2,5 \times 10^6$  de rotation.

La curva de carga lateral admisible se basa en vida util de cojinete de  $2.5 \times 10^6$  revoluciones.

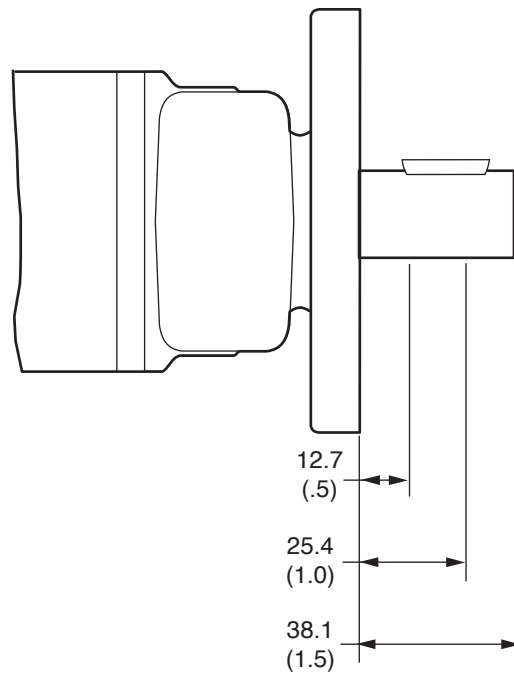

English equivalents for metric specifications are shown in ( ).

**Code: AM**

**SAE "A" 2 Bolt,  
 5/16-18 UNC  
 Manifold**

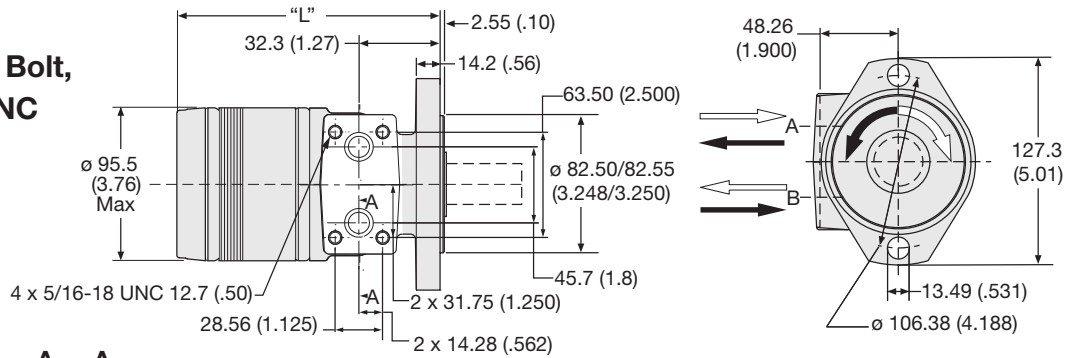

**A - - A**

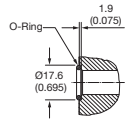

Motor with manifold mount is supplied with 2 O-rings.  
 Zum Motor mit Universalanschluß werden 2 O-Ringe geliefert.  
 Deux joints toriques sont livrés avec les moteurs a plan de raccordement universel.  
 Il blocchetto connessioni è corredato da 2 OR.

Code AP	disp.	0036	0045	0050	0065	0080	0100	0130	0165	0195	0230	0260	0295	0330	0365	0390
<b>Weight/Gewicht</b>	<b>kg</b>	<b>5.38</b>	<b>5.46</b>	<b>5.54</b>	<b>5.67</b>	<b>5.81</b>	<b>5.88</b>	<b>6.19</b>	<b>6.45</b>	<b>6.74</b>	<b>6.93</b>	<b>7.23</b>	<b>7.39</b>	<b>7.71</b>	<b>8.09</b>	<b>8.21</b>
Poids/Peso	(lb)	(11.8)	(12.0)	(12.2)	(12.5)	(12.8)	(13.0)	(13.6)	(14.2)	(14.9)	(15.3)	(15.9)	(16.3)	(17.0)	(17.8)	(18.1)
<b>Length</b>	<b>"L" mm</b>	<b>119.1</b>	<b>120.1</b>	<b>121.6</b>	<b>124.8</b>	<b>127.9</b>	<b>131.1</b>	<b>137.5</b>	<b>143.8</b>	<b>150.2</b>	<b>156.5</b>	<b>162.9</b>	<b>169.2</b>	<b>175.6</b>	<b>184.2</b>	<b>188.3</b>
	"L" (in)	(4.69)	(4.73)	(4.79)	(4.91)	(5.04)	(5.16)	(5.41)	(5.66)	(5.91)	(6.16)	(6.41)	(6.66)	(6.91)	(7.25)	(7.41)

**Code: AP**

**SAE "A" 2 Bolt,  
 1/2-14 NPTF**

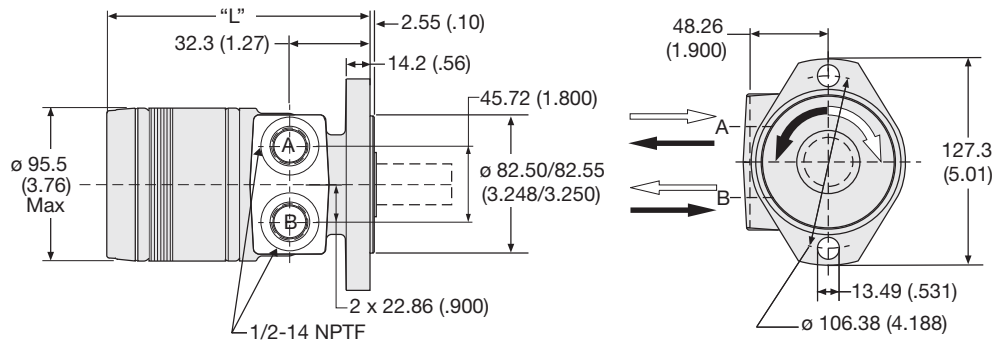

Code AP	disp.	0036	0045	0050	0065	0080	0100	0130	0165	0195	0230	0260	0295	0330	0365	0390
<b>Weight/Gewicht</b>	<b>kg</b>	<b>5.38</b>	<b>5.46</b>	<b>5.54</b>	<b>5.67</b>	<b>5.81</b>	<b>5.88</b>	<b>6.19</b>	<b>6.45</b>	<b>6.74</b>	<b>6.93</b>	<b>7.23</b>	<b>7.39</b>	<b>7.71</b>	<b>8.09</b>	<b>8.21</b>
Poids/Peso	(lb)	(11.8)	(12.0)	(12.2)	(12.5)	(12.8)	(13.0)	(13.6)	(14.2)	(14.9)	(15.3)	(15.9)	(16.3)	(17.0)	(17.8)	(18.1)
<b>Length</b>	<b>"L" mm</b>	<b>119.1</b>	<b>120.1</b>	<b>121.6</b>	<b>124.8</b>	<b>127.9</b>	<b>131.1</b>	<b>137.5</b>	<b>143.8</b>	<b>150.2</b>	<b>156.5</b>	<b>162.9</b>	<b>169.2</b>	<b>175.6</b>	<b>184.2</b>	<b>188.3</b>
	"L" (in)	(4.69)	(4.73)	(4.79)	(4.91)	(5.04)	(5.16)	(5.41)	(5.66)	(5.91)	(6.16)	(6.41)	(6.66)	(6.91)	(7.25)	(7.41)

English equivalents for metric specifications are shown in ( ).

**Code: AS**

**SAE "A" 2 Bolt,  
 7/8-14 SAE**

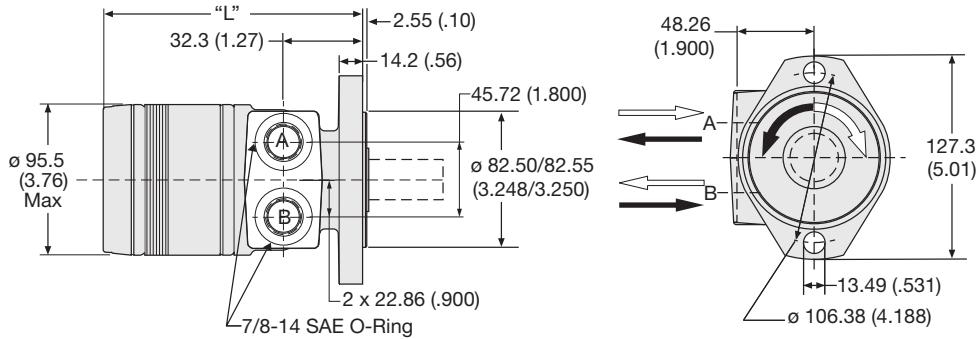

Code AP	disp.	0036	0045	0050	0065	0080	0100	0130	0165	0195	0230	0260	0295	0330	0365	0390
<b>Weight/Gewicht</b>	<b>kg</b>	<b>5.38</b>	<b>5.46</b>	<b>5.54</b>	<b>5.67</b>	<b>5.81</b>	<b>5.88</b>	<b>6.19</b>	<b>6.45</b>	<b>6.74</b>	<b>6.93</b>	<b>7.23</b>	<b>7.39</b>	<b>7.71</b>	<b>8.09</b>	<b>8.21</b>
Poids/Peso	(lb)	(11.8)	(12.0)	(12.2)	(12.5)	(12.8)	(13.0)	(13.6)	(14.2)	(14.9)	(15.3)	(15.9)	(16.3)	(17.0)	(17.8)	(18.1)
<b>Length</b>	<b>"L" mm</b>	<b>119.1</b>	<b>120.1</b>	<b>121.6</b>	<b>124.8</b>	<b>127.9</b>	<b>131.1</b>	<b>137.5</b>	<b>143.8</b>	<b>150.2</b>	<b>156.5</b>	<b>162.9</b>	<b>169.2</b>	<b>175.6</b>	<b>184.2</b>	<b>188.3</b>
	"L" (in)	(4.69)	(4.73)	(4.79)	(4.91)	(5.04)	(5.16)	(5.41)	(5.66)	(5.91)	(6.16)	(6.41)	(6.66)	(6.91)	(7.25)	(7.41)

**Code: FM**

**4 Bolt w/3/8-16 Thd,  
 5/16-18 UNC Manifold**

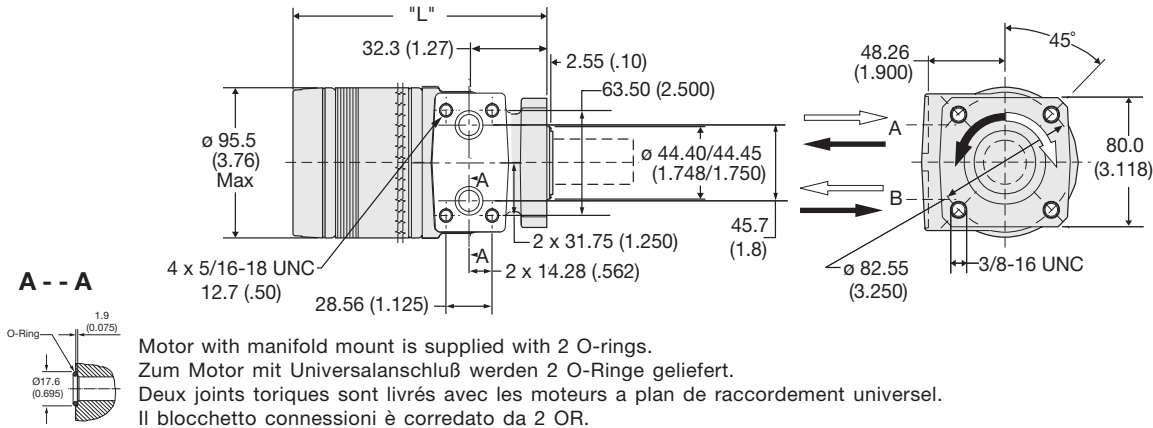

Code FM	disp.	0036	0045	0050	0065	0080	0100	0130	0165	0195	0230	0260	0295	0330	0365	0390
<b>Weight/Gewicht</b>	<b>kg</b>	<b>5.91</b>	<b>6.03</b>	<b>6.12</b>	<b>6.26</b>	<b>6.35</b>	<b>6.49</b>	<b>6.76</b>	<b>7.03</b>	<b>7.35</b>	<b>7.58</b>	<b>7.80</b>	<b>8.07</b>	<b>8.35</b>	<b>8.66</b>	<b>8.80</b>
Poids/Peso	(lb)	(13.1)	(13.3)	(13.5)	(13.8)	(14.0)	(14.3)	(14.9)	(15.5)	(16.2)	(16.7)	(17.2)	(17.8)	(18.4)	(19.1)	(19.4)
<b>Length</b>	<b>"L" mm</b>	<b>119.1</b>	<b>120.1</b>	<b>121.6</b>	<b>124.8</b>	<b>127.9</b>	<b>131.1</b>	<b>137.5</b>	<b>143.8</b>	<b>150.2</b>	<b>156.5</b>	<b>162.9</b>	<b>169.2</b>	<b>175.6</b>	<b>184.2</b>	<b>188.3</b>
	"L" (in)	(4.69)	(4.73)	(4.79)	(4.91)	(5.04)	(5.16)	(5.41)	(5.66)	(5.91)	(6.16)	(6.41)	(6.66)	(6.91)	(7.25)	(7.41)

English equivalents for metric specifications are shown in ( ).



**Code: FP**

**4 Bolt w/3/8-16 Thd,  
 1/2-14 NPTF**

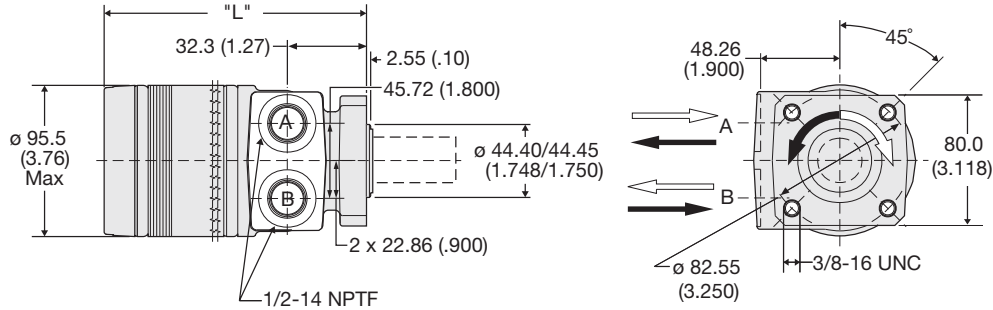

Code FP	disp.	0036	0045	0050	0065	0080	0100	0130	0165	0195	0230	0260	0295	0330	0365	0390
<b>Weight/Gewichtkg</b>	<b>5.91</b>	<b>6.03</b>	<b>6.12</b>	<b>6.26</b>	<b>6.35</b>	<b>6.49</b>	<b>6.76</b>	<b>7.03</b>	<b>7.35</b>	<b>7.58</b>	<b>7.80</b>	<b>8.07</b>	<b>8.35</b>	<b>8.66</b>	<b>8.80</b>	
Poids/Peso (lb)	(13.1)	(13.3)	(13.5)	(13.8)	(14.0)	(14.3)	(14.9)	(15.5)	(16.2)	(16.7)	(17.2)	(17.8)	(18.4)	(19.1)	(19.4)	
<b>Length</b>	<b>"L" mm</b>	<b>119.1</b>	<b>120.1</b>	<b>121.6</b>	<b>124.8</b>	<b>127.9</b>	<b>131.1</b>	<b>137.5</b>	<b>143.8</b>	<b>150.2</b>	<b>156.5</b>	<b>162.9</b>	<b>169.2</b>	<b>175.6</b>	<b>184.2</b>	<b>188.3</b>
"L" (in)	(4.69)	(4.73)	(4.79)	(4.91)	(5.04)	(5.16)	(5.41)	(5.66)	(5.91)	(6.16)	(6.41)	(6.66)	(6.91)	(7.25)	(7.41)	

**Code: FS**

**4 Bolt w/3/8-16 Thd,  
 7/8-14 SAE**

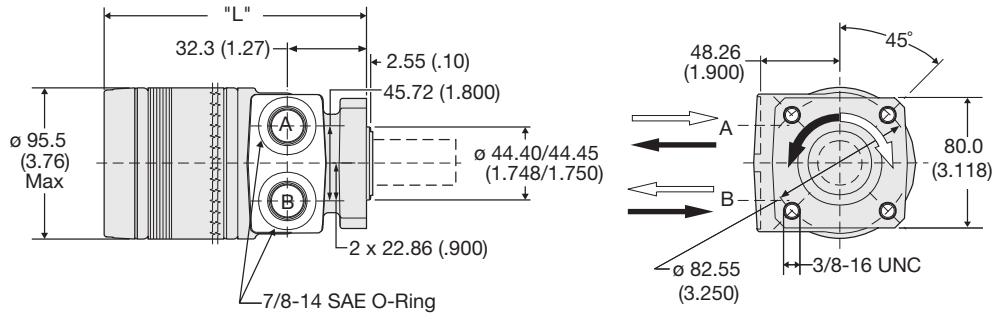

Code FP	disp.	0036	0045	0050	0065	0080	0100	0130	0165	0195	0230	0260	0295	0330	0365	0390
<b>Weight/Gewichtkg</b>	<b>5.91</b>	<b>6.03</b>	<b>6.12</b>	<b>6.26</b>	<b>6.35</b>	<b>6.49</b>	<b>6.76</b>	<b>7.03</b>	<b>7.35</b>	<b>7.58</b>	<b>7.80</b>	<b>8.07</b>	<b>8.35</b>	<b>8.66</b>	<b>8.80</b>	
Poids/Peso (lb)	(13.1)	(13.3)	(13.5)	(13.8)	(14.0)	(14.3)	(14.9)	(15.5)	(16.2)	(16.7)	(17.2)	(17.8)	(18.4)	(19.1)	(19.4)	
<b>Length</b>	<b>"L" mm</b>	<b>119.1</b>	<b>120.1</b>	<b>121.6</b>	<b>124.8</b>	<b>127.9</b>	<b>131.1</b>	<b>137.5</b>	<b>143.8</b>	<b>150.2</b>	<b>156.5</b>	<b>162.9</b>	<b>169.2</b>	<b>175.6</b>	<b>184.2</b>	<b>188.3</b>
"L" (in)	(4.69)	(4.73)	(4.79)	(4.91)	(5.04)	(5.16)	(5.41)	(5.66)	(5.91)	(6.16)	(6.41)	(6.66)	(6.91)	(7.25)	(7.41)	

English equivalents for metric specifications are shown in ( ).

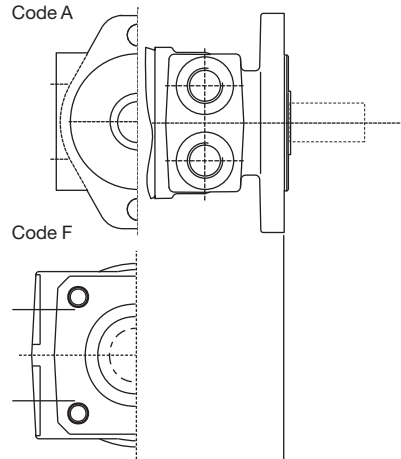

**Code: 09**

**1" Straight with  
0.38" Crosshole**

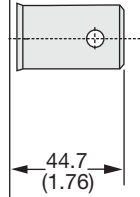

**Code: 10**

**1" Keyed**

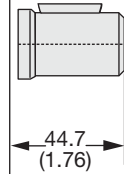

**Code: 11**

**1" 6B Spline**

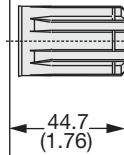

**Code: 13**

**Long 1" Keyed**

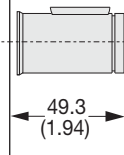

English equivalents for metric specifications are shown in ( ).

001 TC.indd, js

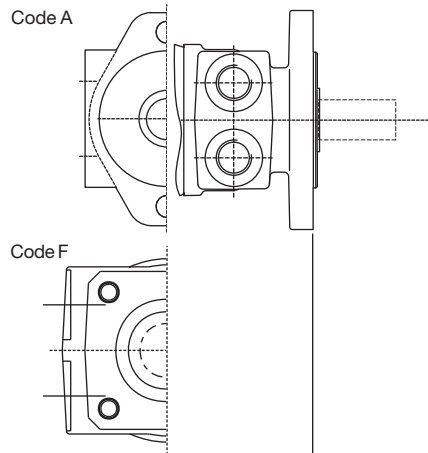

**Code: 21**  
**Corrosion Resistant**

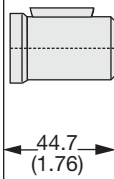

**Code: 26**  
**25mm Keyed**  
**with 8mm Key**

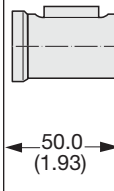

English equivalents for metric specifications are shown in ( ).

**Code: 09**

**1" Straight with  
 0.38" Crosshole**



**Code: 10**

**1" Keyed**

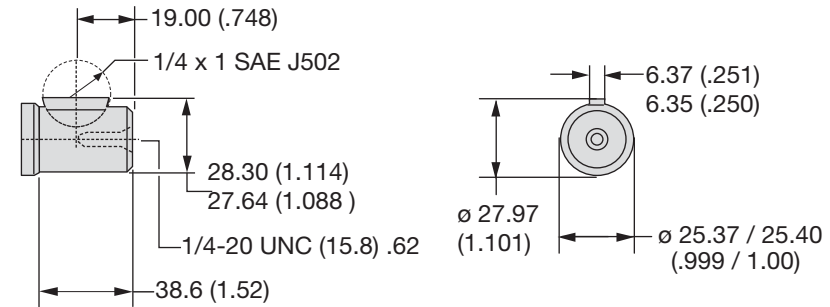

**Code: 11**

**1" 6B Spline**

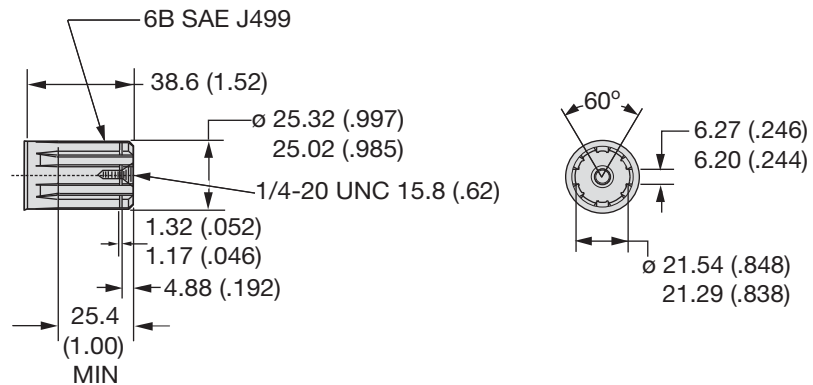

**Code: 13**

**Long 1" Keyed**

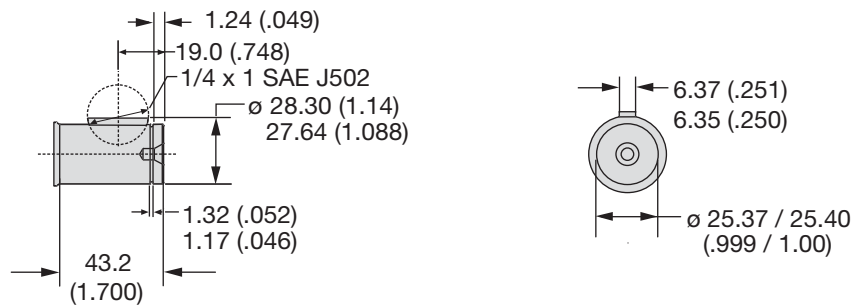

English equivalents for metric specifications are shown in ( ).

001 TC.indd.js

**Code: 21**

**Corrosion Resistant**

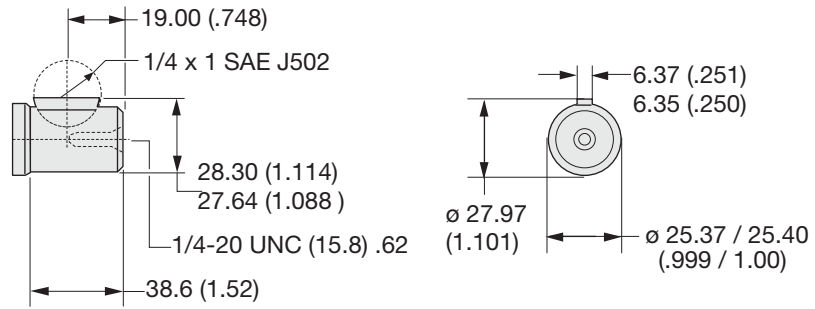

**Code: 26**

**25mm Keyed  
with 8mm Key**

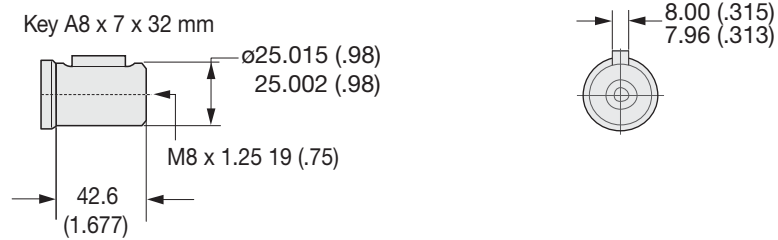

English equivalents for metric specifications are shown in ( ).

001 TC.indd, js

